

Construction Design And Drive System On Plastic Bolt Printing Machine With Msme Scale

Maulana Muhammad*¹  Nur, Riki Effendi² 

^{1,2} Department of Mechanical Engineering, Faculty of Engineering, Muhammadiyah University Jakarta, Jakarta, Indonesia

*Corresponding Author: maulanamuhamad0312@gmail.com

ARTICLE INFO

Article history:

E-ISSN: 2809-3410

P-ISSN: 0216-7492

How to cite:

Maulana Muhammad dan Nur, Riki Effendi “construction design and drive system on plastic bolt printing machine with msme scale” Journal Dinamis, vol. 11, no. 1, June. 2023, doi : 10.32734/dinamis.v11i1.12245.

ABSTRACT

Plastic screw molding machine is one of the important equipment in the manufacturing industry, including micro, small and medium scale (MSMEs). The purpose of this research is to design an efficient and reliable construction and drive system for plastic screw molding machines with MSME scale. This research involved a literature study on printing presses, needs analysis, conceptual design, simulation analysis, prototyping, testing, evaluation, and improvement. Printing machines or molding machines are usually used in large companies, therefore the author intends to make the design and design of printing machines or molding machines simple and can be used by the public at an affordable price. Plastic pellets of the LLDPE type are used for testing the manufacture of plastic bolts using a plastic bolt molding machine that has been designed and made by the author. In this research method the author only discusses component calculations, namely electric motor calculations, pulley calculations, peg calculations, v-belt calculations, and load calculations on the frame. The working system of this plastic bolt molding machine is that first the band heater is turned on first, then the electric motor system is turned on, and after that the LLDPE plastic pellets are put into the container. The plastic pellets will be pushed using a screw which is driven by an electric motor and heated using a band heater, after which the molten plastic pellets come out and immediately enter the mold or molding. In the results of the first test using a temperature of 80 o C and spending 4.36 minutes in a plastic bolt, in the second test using a temperature of 150 o C and spending 2.50 minutes in a plastic screw, and in the third test using a temperature 120 o C and spent 3.30 minutes in one plastic screw.

Keyword: Design, LLDPE plastic pellets, molding

ABSTRAK

Mesin cetak ulir plastik merupakan salah satu peralatan penting dalam industri manufaktur, termasuk skala mikro, kecil, dan menengah (UMKM). Tujuan dari penelitian ini adalah merancang konstruksi dan sistem penggerak yang efisien dan handal untuk mesin plastic screw moulding skala UMKM. Penelitian ini meliputi studi literatur tentang mesin cetak, analisis kebutuhan, desain konseptual, analisis simulasi, prototyping, pengujian, evaluasi, dan perbaikan. Mesin cetak atau mesin moulding biasanya digunakan pada perusahaan besar, oleh karena itu penulis bermaksud membuat rancangan dan desain mesin cetak atau mesin moulding yang sederhana dan dapat digunakan oleh masyarakat dengan harga yang terjangkau. Pelet plastik jenis LLDPE digunakan untuk pengujian pembuatan baut plastik menggunakan mesin pencetak baut plastik yang telah dirancang dan dibuat oleh penulis. Dalam metode penelitian ini penulis hanya membahas perhitungan komponen yaitu perhitungan motor listrik, perhitungan pulley, perhitungan pasak, perhitungan v-belt, dan perhitungan beban pada rangka. Sistem kerja mesin cetak baut plastik ini yaitu pertama band heater dinyalakan terlebih dahulu, kemudian sistem motor listrik dihidupkan, dan setelah itu pelet plastik LLDPE dimasukkan ke dalam wadah. Pelet plastik akan didorong menggunakan ulir yang digerakkan oleh motor listrik dan dipanaskan menggunakan band heater, setelah itu pelet plastik cair akan keluar dan langsung masuk ke cetakan atau moulding. Pada hasil pengujian pertama menggunakan suhu 80 o C dan menghabiskan waktu 4,36 menit pada baut plastik, pada pengujian kedua menggunakan suhu 150 o C dan menghabiskan waktu 2,50 menit pada sekrup plastik, dan pada pengujian ketiga menggunakan suhu 120 o C dan menghabiskan waktu 3,30 menit dalam satu sekrup plastik.

Keyword: Desain, pelet plastik LLDPE, cetakan



This work is licensed under a Creative Commons Attribution-ShareAlike 4.0 International.

<https://doi.org/10.32734/>

1. Introduction

In everyday life, humans are certainly no strangers to objects made of plastic-type materials, there are many types of objects made of plastic-type materials, such as chairs, plates, glasses, and so on. To make a product that uses plastic pellets as raw material, you have to use a printing machine or usually what is often called a molding machine, where the use of this molding machine is the process of changing from plastic pellets to a desired product. In the process of testing the manufacture of plastic bolts, we use raw materials with a type of plastic pellets, which are made from LLDPE. In the initial process, the prepared LLDPE plastic pellets are put into a hopper with a capacity of 5 kg. Then enter a pipe in which there is a screw which functions to push the plastic pellets so that they can enter the next stage of the process, in the next stage the plastic pellets are melted using a band heater whose temperature is regulated using a thermocontroller so that the temperature is stable and so that the plastic pellets can melt smoothly. perfect, if it has melted the plastic pellets will come out and immediately enter the plastic bolt mold, after it cools the mold opens and the plastic bolt drops into the container. So in testing the tool that we are going to design and build, that is to find out the strength of the frame and the drive system on this plastic bolt molding machine and to make plastic bolt molds with the type size M 24.

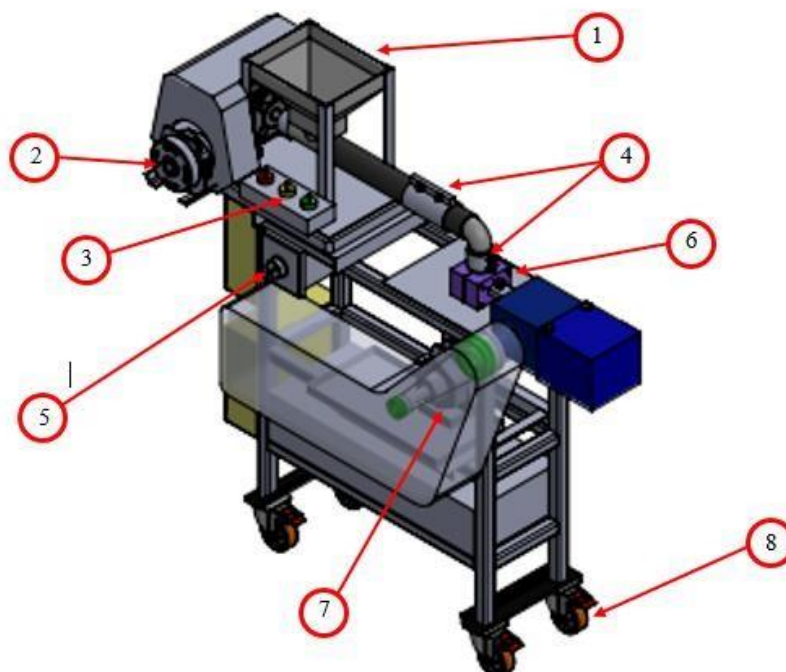

Figure 1 Design of a plastic bolt molding machine

Description :

1. Hoppers
2. Electric motor A
3. Buttons start the machine
4. Heater bands
5. Thermocontrollers
6. Moulding
7. Electric motor B
8. Wheels

2. Methods

In conducting research related to construction design and drive systems on plastic screw molding machines with an MSME scale, the following research methods can be used:

a. Study of literature

Conduct a literature study to gain an in-depth understanding of existing plastic bolt molding machines, drive systems, and constructions. Read the latest developments, technology used, and design methods that have been carried out by previous research.

b. Needs analysis

Perform a needs analysis to identify specific needs in designing a plastic screw molding machine for the MSME scale. Engage with business owners, machine operators and other potential users to obtain input on operational needs, production capacity, desired size of plastic bolts and other relevant factors.

c. Conceptual design

Use a concept-based design approach to produce initial concepts for designing plastic bolt molding machines. Based on the requirements analysis, draw up conceptual sketches and diagrams depicting the possible construction and drive systems.

d. Analysis and simulation

Use simulation and engineering analysis software to validate the resulting design concept. Perform structural analysis, kinematic analysis or other relevant analysis to ensure that the machine construction and propulsion system can handle the expected loads and stresses.

e. Prototypes and trials

Make a prototype of a plastic bolt molding machine based on the conceptual design that has been simulated, conduct practical trials to verify the performance of the machine, drive system, and construction, record and analyze the results of these trials to identify weaknesses and make improvements to the design if necessary.

f. Evaluation and improvement

Evaluation of the prototype based on predetermined performance parameters, such as production efficiency, reliability, production costs, and the quality of the plastic bolts produced, identify weaknesses or problems that arise during testing, and make improvements to the design to improve the performance and effectiveness of the printing press.

g. Implementation

After the design of the plastic bolt molding machine has been tested and improved, prepare implementation recommendations for implementing the molding machine on the MSME scale, provide operational guidance, training and maintenance needed so that the machine can be used properly by MSME.

In this study, the steps as shown in (Figure 2) are carried out , namely the flow chart for making plastic bolt molding machines.

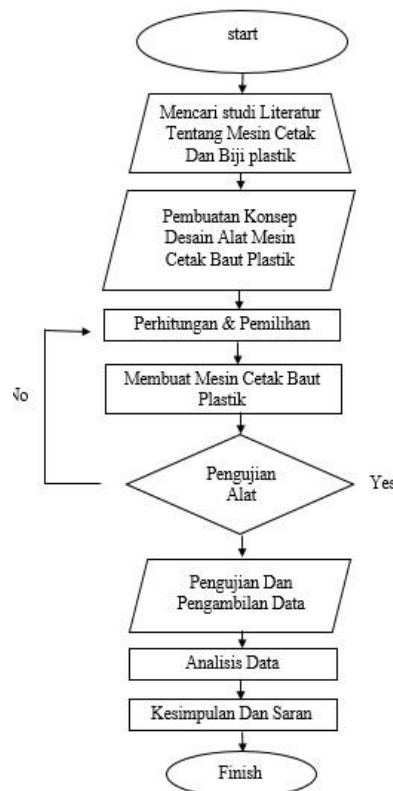

Figure 2 Research Systematic Diagram

3. Results and Discussion

Discussion of materials and tools used

- a. The equipment used to make this plastic bolt molding machine is as follows:
 - Laptops
 - Welding machine
 - Meter
 - Vernier calipers
 - Milling Machine
 - Lathe

- b. The materials used to make this plastic bolt molding machine are as follows:
 - Hollow steel 4 x 4 cm / Galvanized
 - Electric motor □ band heaters
 - thermocontroller
 - 3 inch stainless pipe
 - Gearbox
 - Plastic pellets

Calculation Formulas

- The electric motor is used to rotate the shaft or screw and also to open and close the molding dies. Determine the number of electric motor poles:

$$P = \frac{120 \times F}{n}$$

Information :

P = Number of motor poles F = Frequency (Hz)

n = rotational speed per minute (rpm)

- The gear box ratio is a component to slow down rotation, the gear box ratio uses the WPA 1: 30 type.

Determine the rotational speed of the gear box:

$$N_2 = \frac{N_1}{1}$$

Information :

N₂ = Rotation speed (rpm)

N₁ = Motor rotation speed (rpm)

I = Gear box ratio

- The pulley is a component that functions to open and close the molding mold.

Determine the pulley diameter:

$$D_{out} = D + 2 \cdot c$$

$$B = (Z - 1) \cdot t + 2 \cdot s$$

Information :

D_{out} = Outer diameter of pulley (mm)

B = Pulley width (mm)

Z = Number of belts

- The factor of safety was originally defined as a number dividing the ultimate strength of a material to determine the "working stress" or "design stress". The calculation of the safety factor in a parameter of the success of the safety factor in determining the safety of the construction of both the machine and the framework is seen from its value using the following formula:

$$\square = \frac{\sigma_{yield}}{\sigma_{von\ misses}}$$

Information :

\square = factor of safety σ_{yield} = Material limit stress (mpa)

$\sigma_{von\ misses}$ = Max stress at von misses

Activator Discussion

- It is planned that the electric motor rotates at 1500 rpm and has a frequency of 50 Hz, so to determine the number of poles:

$$P = \frac{120 \times 50}{1500}$$

$$= 4 \text{ polar}$$

Then the type of electric motor used is 4 poles with a rotation of 1500 rpm.

- It is known that the rotation of the electric motor is 1500 rpm, and the gear box used is WPA 40 with a ratio of 1: 30.

$$N_2 = \frac{1500}{30}$$

$$= 50 \text{ rpm}$$

So the speed of the electric motor used to rotate the shaft or screw is 50 rpm.

- Determining the diameter for the pulley to be used is as follows.

It is known that: $e = 12.5$ $c = 3.5$

$$t = 16$$

$$s = 10\text{mm}$$

$$\phi_o = 34o - 40o$$

$$D_{out} = D + 2 \cdot c$$

$$= 69 + 2 \cdot 3,5$$

$$= 76\text{mm}$$

$$B = (1 - 1) \cdot 16 + 2 \cdot 10$$

$$= 20\text{mm}$$

So for the dimensions of the pulleys used the outer diameter is 76 and the inside diameter is 20 mm.

Discussion of Frame Construction

On the frame that will be made on the plastic bolt molding machine, it uses materials with the type of material, namely galvanized or what is commonly called hollow iron using a size of 4 x 4 cm and a thickness of 2 mm.



Figure 3 Plastic bolt molding machine framework

Table 1 Types of loads used for frame testing

Load name	Load Image	Load Details
Force-1		<p>Entities: 8 face(s)</p> <p>Type: apply normal forces Values: 2,500 N</p>

In the strength analysis of the plastic bolt molding machine frame construction, an application is used, namely solidwork to find out how strong the plastic bolt molding machine frame is against the load received. The following is an analysis of the results of a frame load simulation on a plastic bolt molding machine. Assumed loads for trials on the simulated strength of the frame against the load received.

a. Change of shape (Displacement)

The most curved part of the bolt molding machine frame is the reddest area of 0.266 mm in the center section.

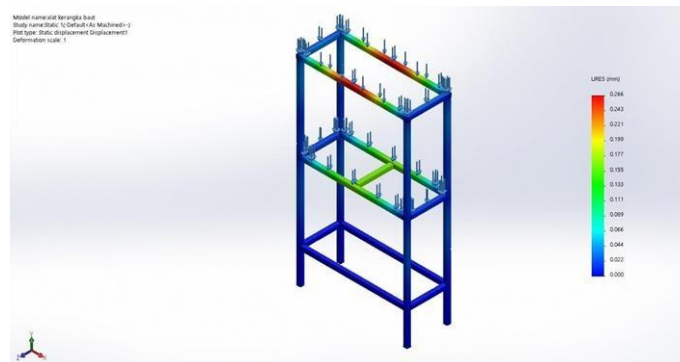

Figure 4 Results of displacement analysis on the frame

b. stress stress (Stress)

In this main frame, the largest stress is $2.039 \times 10^8 \text{ N/m}^2$ and the smallest stress is $3.172 \times 10^3 \text{ N/m}^2$.

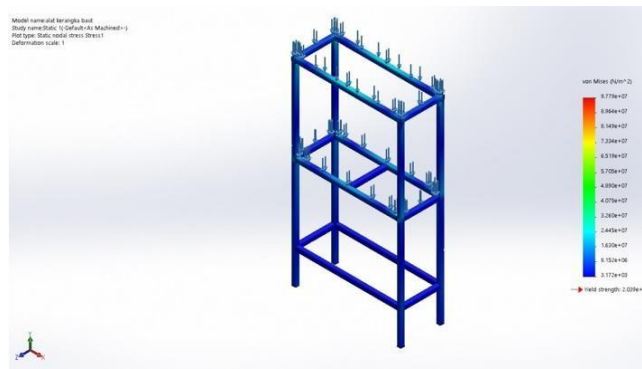

Figure 5 Results of stress analysis on the frame

c. safety factor

The results of the calculation process show where the condition of the frame after calculations using the software explained that the yield strength has a value of $2.039 \times 10^8 \text{ N/m}^2$ from the maximum stress with a value of $3.172 \times 10^3 \text{ N/m}^2$. To calculate the safety factor, it can be calculated as follows:

$$\eta = \frac{\sigma_{yield}}{\sigma_{von\ misses}} = \frac{2,039 \times 10^8}{3,172 \times 10^3} = 64.281,2$$

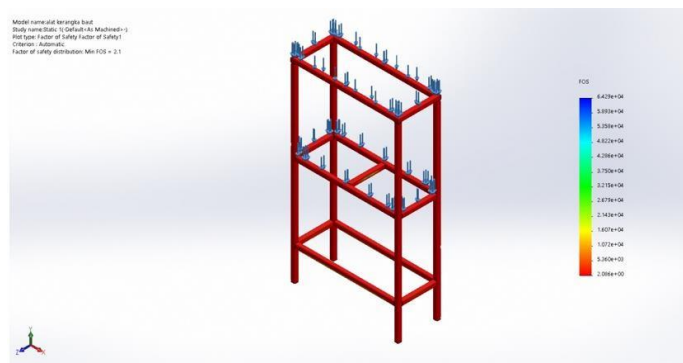

Figure 6 Results of safety factor analysis

Test result

In testing this machine made plastic bolts with the main ingredient, namely plastic pellets of the LLDPE type, this test was carried out 3 times at different temperatures. The following are the results of testing the plastic bolt molding machine:

Experiment I

In the trials of making this first plastic screw using a temperature of $80 \text{ }^\circ\text{C}$, to process 1 plastic bolt at $80 \text{ }^\circ\text{C}$ it took about 4.35 minutes in 1 plastic bolt.



Figure 7 Experimental results I

a. Experiment II

In the trials of making this second plastic screw using a temperature of 150 °C, to process 1 plastic bolt at 150 °C it took about 2.50 minutes in one plastic screw.



Figure 8 Results of experiment II

b. Trial III

In the trials of making this second plastic screw using a temperature of 120 °C, to process 1 plastic bolt at 120 °C it took about 3.30 minutes in one plastic screw.



Figure 9 Experiment III results

4. Conclusion

From the results of the design and manufacture of this plastic bolt molding machine, it can be concluded as follows:

a. Conclusion .The conclusions obtained from the design and testing of this plastic screw machine are that the electric motor used is a 4-valve electric motor type which has 1500 rpm and is then transmitted by a gear box with a WPA 40 type ratio of 1: 30, for pulleys used which are made of material with a type of aluminum which has a diameter of 72.2 mm. In the framework simulation using the solidworks application using a type of material, namely galvanized steel in the frame trial, then at the main frame stress stress the largest stress is $2.036 \times 10^8 \text{ N/m}^2$ and the smallest stress is $3.172 \times 10^3 \text{ N/m}^2$, and the results of the calculation process show where the condition of the framework after calculations using the software is explained that the yield strength has a magnitude with a value of $2.039 \times 10^8 \text{ N/m}^2$ of the maximum stress with a value of $3.172 \times 10^3 \text{ N/m}^2$.

b. Suggestion

In this research, it is limited only to discussing theoretical design, therefore there is a need for further research with the aim of building additional mechanisms for an automated system that is even better than the previous one, for molds / moldings to be even more perfect in design and manufacturing processes on the

mould/molding, and further research should be needed using a cooling system so that the plastic bolt cools quickly in the mould/molding.

References

- [1] (irvan, 2016), "Analysis of Polyethylene Terphthalate (PET) Plastic Waste Melting into Plastic Seeds Through Plastic Melting Tool Tests". Faculty of Engineering, Mercu Buana University, Jakarta.
- [2] (jamiatul , arisandi, ahmad, asnawi, & novri, 2022), "Design of a Centrifugal Casting Machine for Making Geopolymer Composite Pipes". Faculty of Engineering, University of Lampung.
- [3] (ahmad , muh. arsyad , muh. devo, muh. asrul , & mujahid , 2021), "Design of a Plastic Injection Machine With a Pneumatic Pressing System". Department of Mechanical Engineering, Ujung Padang State Polytechnic, Makassar.
- [4] (putu, k. rihendra , & I.N. pasek , 2020), "Design of a Vertical Screw Molding Machine with a Dinamo Starter as a Plastic Waste Liquefier". Mechanical Engineering Education Study Program, Ganesha University of Education, Singaraja, Indonesia.
- [5] (M. ghiffari, 2021), "The Effect of Barrel Tube Heat Transfer on Plastic Extruder Machines". Mechanical Engineering Study Program, Muhammadiyah University of North Sumatra, Medan.
- [6] (untoro) , "Various Methods of Converting Plastic Waste Into Fuel Oil".
- [7] Mechanical Engineering Department, Janabadra University, Yogyakarta.
- [8] (imam), Properties and characteristics of plastic materials and additives.
- [9] (arieyanti , jatmiko, aeda, & siti), Study of the establishment of a plastic seed business in Pati district, Central Java.
- [10] (Ferdinand & E. Russel , 1989), "Mechanics For STATIC ENGINEERS". Elangga: Jakarta.
- [11] (Prof. Dr. Ir. Darmir, 2011), "Machine Elements". Citra Treasure Prima: Jakarta.
- [12] (Ir. Sularso, MSME & Kiyokatsu, Cetakan ke11 Tahun 2013), "Basic Planning And Selection Of Machine Elements". Pt. Pradnya Paramita: Jakarta.
- [13] Albar, A & Guan, Z. (2019). Design and manufacturing of plastic injection molding tool with low – cost metal additive manufacturing technology. Journal of manufacturing and materials processing , 3(1), 19. doi: 10.3390/jmmp3010019
- [14] Chiang, H. P., Chiang, C. C., & Hsu, K. C. (2018). Design and analysis of an injection molding machine for plastic chair. Advances in materials science and engineering, 2018, 1 – 10. doi: 10.1155/2018/3151804
- [15] Doran, R. G., & Scanlan, J. C. (2016). Develoment of a desktop injection moulding machine for educational use. Procedia CIRP, 49, 269 – 274. Doi: 10.1016/j.procir.2016.04.085
- [16] 10.1016/j.procir.2016.04.085
- [17] Gassara, A., Mhiri, H., & Haddar, M. (2016). Design and simulation of plastic injection molding process for printing rollers. Procedia CIRP, 49, 95 – 100. Doi: 10.1016/j.procir.2016.04.031
- [18] Kalla, P., Tiwari, V., & Saini, K. (2020). Design and analysis of injection moulding machine for polystyrene handle. Materials today: proceedings, 26(2), 3130 – 3134. doi: 10.1016/j.matpr.2020.04.596
- [19] 26(2), 3130 – 3134. doi: 10.1016/j.matpr.2020.04.596
- [20] Omer, I. (2019). Design and fabrication of a low – cost injection molding machine for prototyping and short – run production. Engineering, technology & applied science research, 9(3), 4231 – 4234. doi: 10.48084/etasr.2773
- [21] 10.48084/etasr.2773
- [22] Rjput, R., Kumar, V., & Raj, S. (2019). Design fabrication of mini injection moulding machine for small scale industries. IOP conference series: materials science and engineering, 597, 012027. doi: 10.1088/1757 – 899x/1/012027
- [23] Widiastuti, I., Sudaryanto, S., & Prasetya, B. (2020). Design injection molding machine with multi cavity mold for plastic gear production. IOP conference series: materials science and engineering, 711, 012007. doi: 10.1088/1757 – 899x/711/1/012007
- [24] 10.1088/1757 – 899x/711/1/012007