



Jurnal KORIDOR

Journal homepage: <https://talenta.usu.ac.id/koridor/>



Thermal Image of Sun Orientation and Openings in Residential Buildings with Modern Tropical Design Concept in Medan City

Harry Wibowo^{*1}, Dicky Andrea Sembiring²

¹Architecture Departement, Faculty of Engineering, Universitas Negeri Medan, Medan, 20221, Indonesia

²Architecture Departement, Faculty of Engineering, Universitas Sumatera Utara, Medan, 20155, Indonesia

*Corresponding Author: harry_ft@unimed.ac.id

ARTICLE INFO

Article history:

Received 28 April 2023

Revised 12 June 2023

Accepted 27 June 2023

Available online 27 June 2023

E-ISSN: 2721-3463

P-ISSN: 2086-910X

How to cite:

Wibowo, H. Sembiring, Dicky A. (2023). Thermal Image of Sun Orientation and Openings in Residential Buildings with Modern Tropical Design Concept in Medan City. *Jurnal Koridor*, 14(1), 38-47.

ABSTRACT

This study aims to analyze thermal imagery of the sun's orientation and the formation of openings in residential houses with a modern tropical design concept in Medan. The method used is temperature measurement and building thermal identification using a digital thermal imaging tool, namely Flir CX-3, which is carried out during the day, as well as measuring the WWR (window-to-wall ratio) value of the building. The results of the thermal image analysis show that the North-South orientation gets lower temperatures compared to the East-West orientation, even though it has a larger WWR value of 12.9% and 20.9%. Based on the results of this analysis, it is suggested to consider the orientation of the sun in designing residential houses in the city of Medan. Houses with a North-South orientation are the best choice for maximum thermal comfort and natural lighting, supported by large openings as one of the characteristics of modern tropical architecture.

Keyword: Thermal Image, Orientation, Aperture, WWR (Window-to-Wall Ratio), Flir CX-3, and Tropical Modern

ABSTRAK

Penelitian ini bertujuan untuk menganalisis citra *thermal* dalam hubungannya dengan orientasi matahari dan banyaknya bukaan pada rumah tinggal di Kota Medan. Metode yang digunakan adalah pengukuran suhu dan pengambilan citra *thermal* menggunakan alat pencitraan *thermal* digital yaitu Flir CX-3 yang dilakukan pada siang hari, serta mengukur nilai WWR (*window to wall ratio*) pada bangunan tersebut. Hasil analisis citra *thermal* menunjukkan bahwa, arah orientasi Utara-Selatan memiliki suhu yang lebih rendah dibandingkan dengan orientasi Timur-Barat walaupun memiliki nilai WWR yang lebih besar yaitu 12,9% dan 20,9%. Berdasarkan hasil analisis ini, disarankan untuk mempertimbangkan orientasi matahari dalam merancang rumah tinggal di Kota Medan. Rumah dengan berorientasi Utara-Selatan menjadi pilihan terbaik untuk mendapatkan kenyamanan *thermal* bangunan, dengan didukung oleh bukaan yang besar. Hal ini terbukti tidak terlalu mempengaruhi suhu udara didalam bangunan. Sebaliknya untuk arah Timur-Barat sedapat mungkin untuk mengurangi luas bukaan, hal ini disebabkan untuk mengurangi paparan sinar matahari masuk ke dalam bangunan.

Keyword: Citra *Thermal*, Orientasi, WWR (*Window to Wall Ratio*), Flir CX-3, dan Kenyamanan *Thermal*.



This work is licensed under a Creative Commons Attribution-ShareAlike 4.0 International.

<http://doi.org/10.26594/register.v6i1.idarticle>

1. Introduction

Indonesia is one of the countries on the equator with a tropical climate. Throughout the year, there are (two) types of seasons: the rainy and dry seasons (Satwiko, 2009). The intensity of rainfall that falls is higher than in the dry season. Therefore, Indonesia is a country with a wet tropical climate (Karyono,2016; Dewi, 2020).

Medan City is one of the cities in Indonesia with an average where the reception of solar radiation is relatively high (Prasetya, Munawar, & Chesoh, 2020). Data at Sampali Station in 2020 showed that the city of Medan has a minimum temperature of 21°C, a maximum temperature of 36°C, and an average humidity of 70-80%.

This relatively high average temperature not only negatively affects thermal comfort in buildings but also affects the performance of its occupants (Talarosa, 2005). To create an excellent residential building design concept in tropical climates, it is necessary to approach the surrounding climate; the resulting form of residential design must respond to surrounding climatic conditions to create maximum thermal comfort for its residents (Karyono T. H., 2013).

Tropical modern architecture is one approach to architectural design concepts that can adapt to tropical climates (Ghassan et al., 2021; Lissimia et al., 2022). Tropical modern architecture is designed to create thermal comfort and energy savings in a building with a modern design. The combination of modern concepts and natural touches makes buildings with a modern tropical style a new trend in recent years.

One of the characteristics of modern tropical architecture is the wide opening and the use of glass material to continue sunlight while giving a modern impression (Lissimia & Gustianingrum, 2022). The presence of large glass openings not only provides natural lighting but can also transmit the sun's heat into the building. The entry of Maharani rays is closely related to the direction of sunlight that carries the heat (radiation) of the sun. So planners need to consider the direction of sunlight or the so-called orientation of the sun toward the building.

Several previous studies have analyzed the effect of solar orientation on the ability to retain heat in housing in Wonorejo, Surakarta, Indonesia. The results showed that the orientation of the building facing South has the best ability to withstand heat than other orientations (Yuuwono, 2011). Another study was conducted (Sari, 2019) regarding the influence of sun orientation on bedrooms in residential houses in Tanjung Morawa sub-district, Deli Serdang Regency, North Sumatra. The method is carried out by measuring using the Trotec BZ-30 data logger measuring instrument, which can record air temperature every 2 seconds. From the measurements carried out for seven days, at 07:00-06:59 WIB on two houses with a West (C1) and South (J2) orientation, it was found that the West-oriented bedroom has the most uncomfortable temperature compared to other orientations.

Reviewing previous studies, we developed the current study as follows. First, we analyzed the effect of aperture formation on buildings with tropical modern architectural styles on the sun's orientation using a digital thermal imaging tool, the CX-3 Fhir. With this method, it can prove directly and clearly (using thermal image images) the acquisition of heat in the object of study. It is essential to conclude the success of the architect's post-occupancy design of the house in the application of the theme it carries, namely tropical models. Second, previous studies concerning the sun's orientation towards buildings were more specific to the material factors that make up the building and the influence of the direction of the building only. At the same time, we analyze the influence of someday orientation based on the factor of existing building openings (Wall Windows Ratio).

Thus, the purpose of this study is to prove not only the direction of the best orientation of the building towards the sun but also the influence of the opening factor on the amount of heat received by the building using digital imaging thermal tools. In addition, this research can provide additional knowledge about the relationship between modern tropical architecture and the optimization of large openings for the comfort of its inner space.

2. Method

The research method carried out in this study uses Quantitative methods. Quantitative research methods are research methods used by researchers using research measuring instruments (instruments) with statistical analysis (Kristanto, 2018).

Data collection techniques consist of two stages: literature study and field observation. First, a literature study was conducted to collect data on the characteristics and characteristics of residential buildings with modern tropical concepts and some references needed in the planning data, such as books, magazines, newsletters, and articles. Second, look for research subjects of residential buildings located in Medan with characteristics of modern tropical concepts. Third, observation and field data were collected on research subjects on April 1, 2023. The data taken include room temperature and thermal images of indoor and outdoor spaces in buildings. The samples were taken at the hour with the highest emission of solar radiation, which is between 12:00-16:00. The fourth step is the comparison of heat gain between rooms based on the opening factor, namely the calculation of WWR (Wall Windows Ratio) in the building and the direction of orientation of the building. In the end, a conclusion can be drawn from this study.

2.1 Temperature Conditions in Medan

The dry season lasts 4.6 months, from March 13 to August 2, with average daily high temperatures above 32°C. The warmest month of the year in Medan is May, with an average high of 32°C and a low of 25°C. At the same time, the rainy season lasts for 2.1 months, from November 16 to January 18, with average daily high temperatures below 31°C. The coldest month of the year in Medan is December, with an average low of 24°C and a high of 30°C. More details can be seen in Figure [1] and Table [1] below.

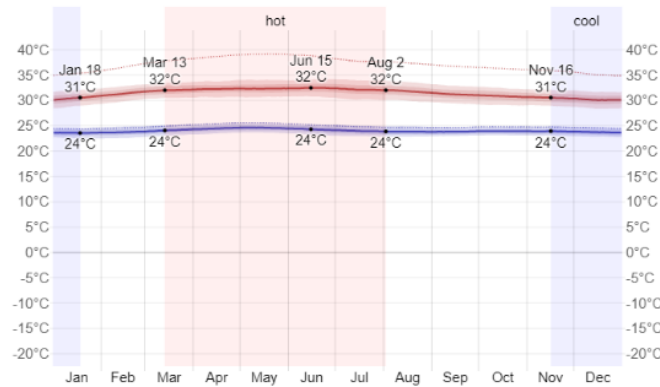

Figure 1. Temperature forecast for 2023 in Medan city

Source: weatherspark, 2023

Table 1. Highest, Lowest and Average temperature forecast for 2023 in Medan

Temp	Jan	Feb	Mar	Apr	May	Jun	Jul	Aug	Sep	Oct	Nov	Dec
High	31°C	31°C	32°C	32°C	32°C	32°C	32°C	32°C	31°C	31°C	31°C	30°C
Low	24°C	24°C	24°C	24°C	25°C	24°C	24°C	24°C	24°C	24°C	24°C	24°C

Source: weatherspark , 2023

From the temperature data of the city of Medan, it was decided that the time of data collection, was in April, which was one of the months with the highest temperature in the city of Medan.

2.2 Object of Study

The object of study is a residential house located on Jalan Mulia Kompek Griya Insan Mulia, Selayang District, Asam Kumbang Village, Medan City. The coordinates of the object of study are 3°33'17.11"N, 98°37'11.24"E. For more research details, the location can be seen in Figure [2] below



Figure 2. Location of the object of study

Source: Google Earth, 2023

This 2-story residential building is located on an area of 10m x 20m, with a total area of ± 250 m². This residential building has the characteristics of the modern tropical concept as mentioned by (Lissimia & Gustianingrum, 2022):

1. The period of square-shaped buildings is the most effective formation for using space and land.
2. Use a roof sloped over 30 degrees to prevent waterlogging during heavy rains.
3. In addition, similar roofs can reduce the effects of heat when entering the dry season.
4. Using materials from nature in the form of exposure bricks and Large glass openings to maximize natural lighting and make a modern impression on the building.

More details can be seen in Figures 3, 4, and 5 below:



Figure 3. Existing Front View of Home Study Objects 2 Floors Residence with Modern Tropical Concept
 Source: Existing Data, 2023



Figure 4 (a) 1st Floor Plan (b) 2nd Floor Plan
 Source: Existing Data, 2023

3. Findings and Discussion

3.1 Sun Orientation of the Object of Study

Orientation is the directional position facing a building located on a particular site. Several factors influence the orientation of the building in the area located near the site. These factors are aspects of lighting (sun) and wind direction. The lighting aspect will affect how much sunlight will be put into the space located in the building, the placement of openings, the dimensions of openings, and the provision of sun shading. Conversely,

the aspect of wind direction wants to affect the position of building openings (D.A Dea Sekar, 2018). More details can be seen in Figures [6] below:

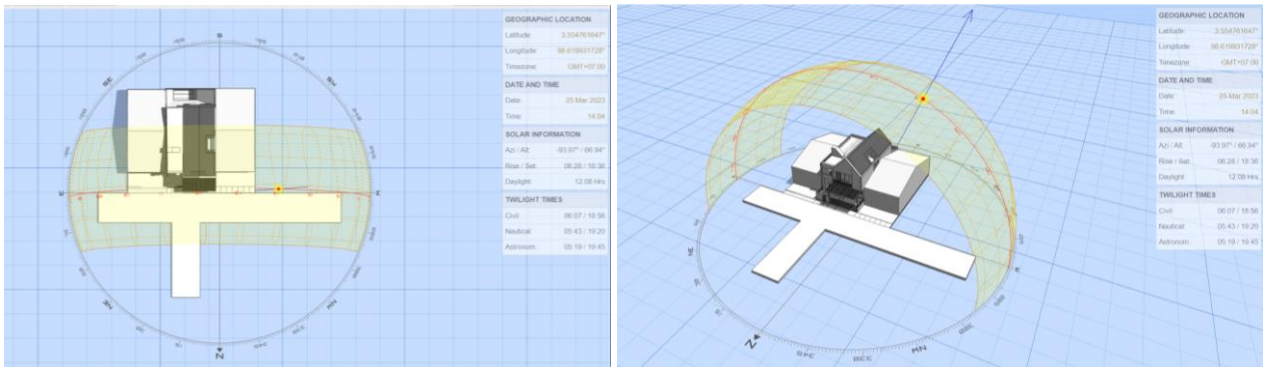

Figure 6. Sun path diagram simulation with 2-storey residential house model

Source: AndrewMarsh.com, 2023

From the results of simulating the sun's orientation towards the direction of the building in the Andrew Marsh.com application with coordinates that match the location of the object of study, it can be concluded that this residential building is a North-South orientation. This is by the position of the plot, which is 10x20 on the shortest side facing the road.

3.2 Formation of Openings in Buildings

There are several types of opening models in this tropical modern house, including:

Table 2. Formation of openings in the object of study of tropical modern houses

No.	Building Orientation	Opening Type
1	North	Glass window 3 leaves size (60x220cm) x 1 Glass window 2 leaf size (60x145cm) x 5
2	South	Sliding glass door 3 leaves size (80x250cm) x 1 Sliding glass window 3 leaf size (90x100cm) x 1 Glass window 2 leaf size (60x145cm) x 2
3	East	Sliding glass door 2 leaf size (80x250cm) x 2
4	West	Glass window 1 leaf size (60x145)x1

Source: Data analysis, 2023

From the results of field observations, the formation of openings in the North and South orientations is the field with the largest area and then followed by the field of openings in the East-West orientation.

3.3 Window to Wall Ratio (WWR)

In general, WWR (Window to wall ratio) can be interpreted as a comparison of the area of the window to the size of the room's wall. The formula used to calculate the value of the wall opening ratio uses the formula used in Chaerani's research. According to (Dwi Chaerani and Djunaedy n.d.), the procedure that can be used to calculate the WWR of the selected field of each building is :

$$WWR = \frac{A_{f1} \text{ Area}}{A_{w1} \text{ Area}} \quad (1)$$

Description :

A_{f1} Area : Overall window area on one field

A_{w1} Area : Overall surface area one field

Based on the results of WWR calculations on this residence, it is known that the orientation of buildings facing South has the most significant number of WWR at 20.9%, and the orientation of buildings facing East has the smallest number of WWR at 1.3% for more details can be seen in table 3 below.

Table 3. WWR calculation of building orientation

Building Orientation	Af1 (m2)	Aw1 (m2)	WWR
North	11,9	92,5	12,9%
South	16,7	80,0	20,9%
East	1,55	122,9	1,3%
West	6,5	111,08	5,9%





Source: Data analysis,2023





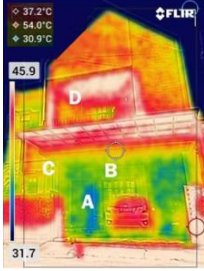

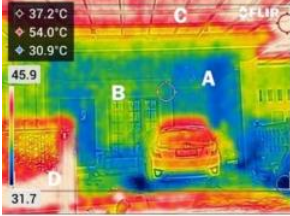
3.4 Thermal Image Analysis of the Object of Study



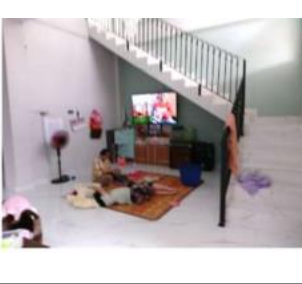
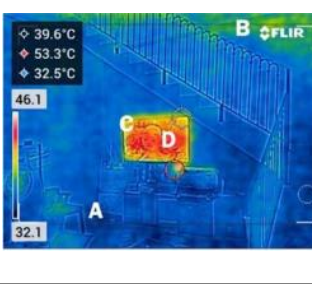

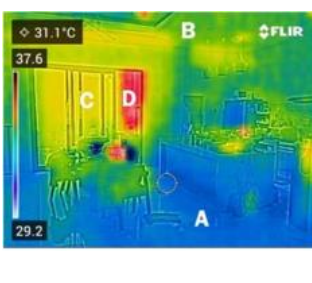

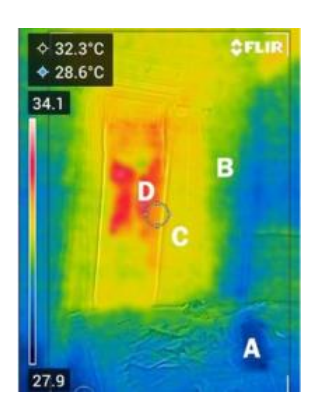

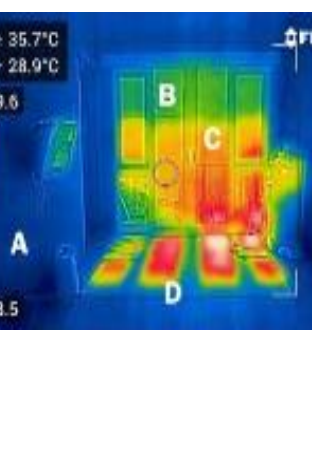
After knowing the largest WWR of the object of study of residential buildings, namely in the South direction, further analysis was carried out by looking at the thermal image of the building using a digital thermal imaging tool, namely Flir CX-3. This thermal imaging tool can display a picture of the thermal distribution of buildings directly, so we can find out which parts of the building have heat input sources.

This thermal image was taken at 14.00 WIB (average maximum temperature of the sun) in April 2023 (one of the hottest months of the year in Medan City). Thermal imagery was taken in all rooms in this residence, including the terrace, living room, guest bedroom, family room, dining room, kitchen, staircase area, upper family room, children's room 1, children's room 2, work hall, and main bedroom. For more, see Table 4 and 5 below.

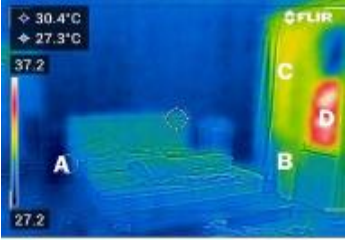
Table 4. The results of thermal and room temperature images on the 1st and 2nd floor of a residential house with a tropical modern architectural concept

Room	Building Image	Thermal Image	Temperature (Noon)
Front Façade			A : 31.7° C B: 33.5° C C: 36.5° C D: 40.5° C
1st floor			
Front terrace			A : 31.7° C B: 33.5° C C: 36.5° C D: 40.5° C
Guest room			A : 31.7° C B: 32.5° C C: 34.5° C D: 38.5° C

Room	Building Image	Thermal Image	Temperature (Noon)
			
Living room			A : 32.1° C B : 33.5° C C : 38.5° C D : 45.5° C
Dining room and kitchen			A : 29.2° C B : 32.5° C C : 35.0° C D : 37.6° C
Guest bedroom			A : 28.0° C B : 30.5° C C : 31.0° C D : 34.1° C
2nd floor			
2nd floor Living room			A : 28.5° C B : 31.5° C C : 34.0° C D : 39.6° C

Room	Building Image	Thermal Image	Temperature (Noon)
Workspace			A : 31.7° C B : 33.5° C C : 36.5° C D : 40.5° C
Master Bedroom			A : 27.2° C B : 30.5° C C : 32.5° C D : 37.2° C
Children's Bedroom 1			A : 27.5° C B : 30.5° C C : 32.5° C D : 34.8° C
Children's Bedroom 2			A : 28.5° C B : 30.5° C C : 32.5° C D : 34.7° C
Staircase area			A : 30.0° C B : 33.5° C C : 36.5° C D : 39.6° C

Source: Data analysis (flir cx-3),2023

From the results of thermal images that have been carried out in each room, it can be concluded that the area in the North orientation plane (living room, guest bedroom, main bedroom, workspace) has an average room temperature of 27-31°C (comfortable), with a WWR of 12.9%. Furthermore, the South orientation (family room, child bedroom 1, child bedroom two, and staircase area) has an average room temperature of 27.5-32°C (comfortable), with a WWR amount of 20.9%. Western orientation (guest bedroom, work room, staircase area, living room) has an average temperature of 30-33°C (less comfortable) with a WWR amount of 5.9%. The Eastern orientation (kitchen, living room, upper living room) has an average temperature of 30-34°C (less comfortable) with a WWR amount of 1.3%.

4. Conclusion

This study analyzes the influence of openings and solar orientation on thermal characteristics in 2-story residential houses that carry the concept of modern tropical architecture in Medan. The findings showed that the part of the building that was oriented in the East-West solar trajectory (longest side) with few openings (Small WWR Value) proved effective in reducing the heat entering the building during the day; this is shown by thermal imaging images that are still within comfortable limits. While the part of the building that is in the North-South orientation (shortest side) with many openings (WWR value is significant) proved not to have much influence on the heat entering the building, this is shown by thermal imaging images that are still within comfortable limits in this residential building even during the day.

The number of openings on the North-South side of this building can help natural air circulation and allow more fabulous air flow into the building, helping to reduce the temperature inside the building. In applying building styles with modern tropical architecture, considering the principle of shade and the orientation of openings in tropical climates will provide good thermal performance.

The effectiveness of these strategies may vary depending on local geographical and environmental conditions, as well as building design and use. Therefore, it is necessary to conduct a careful and comprehensive evaluation in planning and designing energy-efficient and environmentally friendly buildings. These findings can be used in the early stages of further studies.

Acknowledgment

In the process of completing this research, the author received a lot of help and support from various parties involved in it. Therefore, the author wants to thank Allah SWT for bestowing His health and blessings. In addition, thank you to colleagues and reviewers who helped the author complete this paper.

References

- Alfian, W. O. (2018). *Pengaruh Fasad Terhadap Kinerja Energi Pendingin Pada Kantor Pemerintah di Surabaya*. Surabaya: Institut Teknologi Sepuluh November.
- Bahar, F. F. (2017). *Model Pembayangan dan Lansekap Ruang Kota Dalam Sistem Lingkungan Termal Perkotaan Di Daerah Tropis Lembab*. Surabaya: Jurusan Arsitektur Institut Teknologi Sepuluh November.
- D.A Dea Sekar, G. d. (2018). Aplikasi Konsep Arsitektur Tropis Pada Bangunan Smp Alam Lebah Putih Salatiga. *ARSITEKTURA Vol 16*, 5-14.
- Dewi, E. P. (Vol 2, 2020). Penerapan Double Skin Facade Pada Daerah Iklim Tropis. *Jurnal iKRAITH-TEKNOLOGI*.
- Ghassan, M. L. (2021). An evaluation of the tropical architectural concept on the building design for achieving thermal comfort (Case study: engineering faculty of Syiah Kuala university). *IOP Conference Series: Materials Science and Engineering*, (ss. 1–10).
- Karyono, T. (2016). *Arsitektur Tropis - Bentuk, Teknologi, Kenyamanan dan Penggunaan Energi*. Jakarta: Erlangga.
- Karyono, T. H. (2013). *Arsitektur dan Kota Tropis Dunia Ketiga, Suatu Bahasan Tentang Indonesia*. Jakarta: PT. Rajagrafindo Persada.
- Kristanto, V. H. (2018). *Metodologi Penelitian : Pedoman Penulisan Karya Tulis Ilmiah (KTI)*. Yogyakarta: Deepublish.
- Lissimia, F., & Gustianingrum, R. (2022). Modern Tropical Architecture Style on Uluwatu House, Indonesia. *ICECREAM (International Conference on Engineering, Construction, Renewable Energy, and Advanced Materials)* (pp. 1-6). Jakarta : UMJ.
- McMullan, R. (2012). *Environmental Science in Building*. Basingstoke: Palgrave Macmillan.

- Prasetya, T., Munawar, & Chesoh, S. (2020). Different space characteristics of air temperature. *Journal of Physics: Conference Series* , 1517.
- Sari, Y (2019). Pengaruh Orientasi Bangunan Rumah Tinggal terhadap Kondisi Termal Kamar Tidur. *Talenta Conference Series: Energy and Engineering (EE) Vo.2*
- Satwiko, P. (2009). *Fisika Bangunan*. Yogyakarta: CV. Andi Offset.
- Talarosa, B. (2005). Menciptakan Kenyaman Thermal Dalam Bangunan. *Jurnal Sistem Teknik Industri* , Vol 6. No.3.
- weatherspark.(2023).<https://weatherspark.com/y/112741/Average-Weather-inMedan-Indonesia-Year-Round>.Retrieved from <https://weatherspark.com/>.
- Yuuwono, A. B. (2011). Pengaruh Orientasi Bangunan Terhadap Kemampuan Menahan Panas Pada Rumah Tinggal Di Perumahan Wonorejo Surakarta. *Jurnal Teknik Sipil dan Arsitektur*, 10(14).